



# HL59xx Series High Speed Low Noise LDO

## Features

- Low voltage drop:  
0.12V@100mA@VOUT=3.3V(Typ.)
- Standby Mode: 0.1uA
- Low temperature coefficient
- High input voltage (up to 8V)
- Output voltage accuracy: tolerance  $\pm 2\%$
- SOT23、SOT23-3、SOT23-5、SOT89 package

## Applications

- Battery-powered equipment
- Communication equipment
- Mobile phones
- Portable games
- Cameras, Video cameras
- Reference voltage sources

## General Description

The HL59xx series are highly accurate, low noise, CMOS LDO Voltage Regulators. Offering low output noise, high ripple rejection ratio, low dropout and very fast turn-on times, the HL59xx series is ideal for today's cutting edge mobile phone. Internally the HL59xx includes a reference voltage source, error amplifiers, driver transistors, current limiters and phase compensators.

The output voltage is set by current trimming. Voltages are selectable in 100mV steps within a range of 1.2V to 5.0V.

When the CE input pin is low, the fast discharge channel can pass, a built-in pull-down resistor

pulls the output voltage low. Fast discharge function optional.

The HL59xx series is also fully compatible with low ESR ceramic capacitors, reducing cost and improving output stability. This high level of output stability is maintained even during frequent load fluctuations, due to the excellent transient response performance and high PSRR achieved across a broad range of frequencies. The CE function allows the output of regulator to be turned off, resulting in greatly reduced power consumption.

## Order Information

HL59xx①②③④

Designator	Symbol	Description
①②	Integer	Output Voltage
③	X	Package:SOT23
	M	Package:SOT23-3
	M5	Package:SOT23-5
	P	Package:SOT89
④	R	RoHS / Pb Free
	G	Halogen Free

Note: "①②" stands for output voltages. Other voltages can be specially customized

## Block Diagram

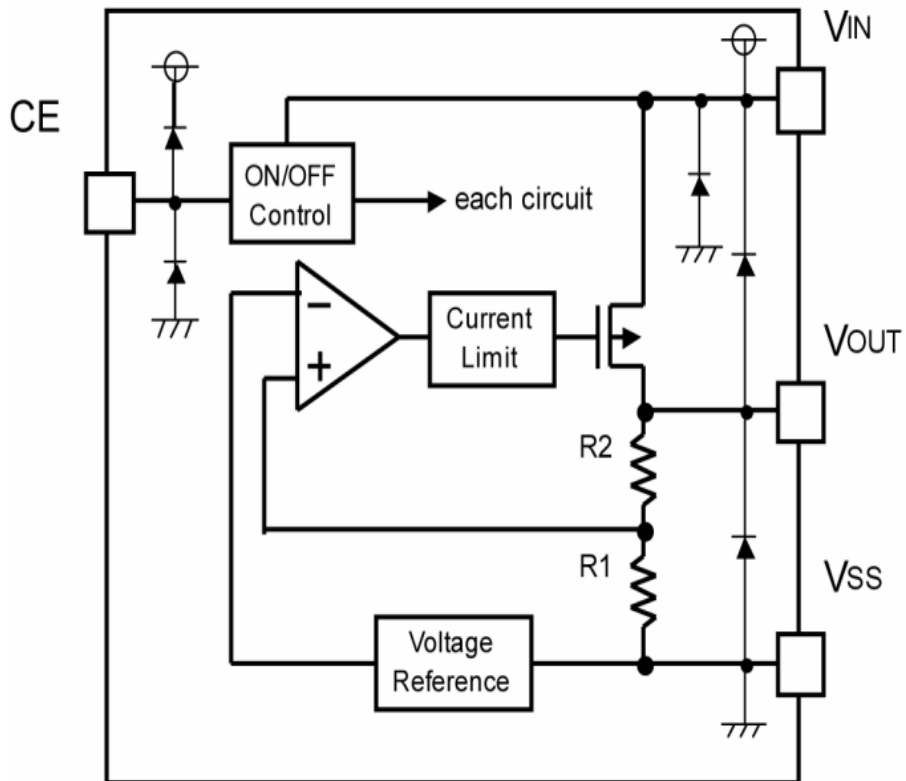

## Package and Pin assignment

SOT23 (Top View)

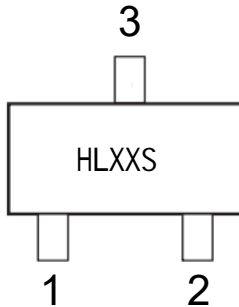

Table1: HL59xxXR series (SOT23 PKG)

PIN NUMBER	SYMBOL	FUNCTION
1	GND	Ground
2	V <sub>OUT</sub>	Output Pin
3	V <sub>IN</sub>	Power Input Pin

SOT23-5 (Top View)

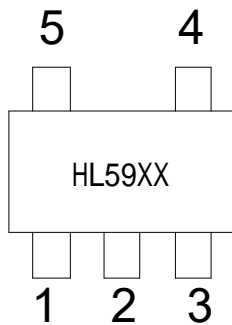

Table2: HL59xxM5R series (SOT23-5 PKG)

PIN NUMBER	SYMBOL	FUNCTION
1	V <sub>IN</sub>	Power Input Pin
2	GND	Ground
3	CE	Chip Enable Pin
4	NC	No Connection
5	V <sub>OUT</sub>	Output Pin

SOT89 (Top View)

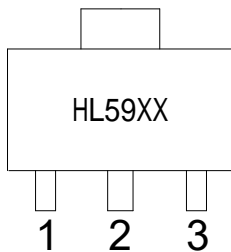

Table3: HL59xxMMR series (SOT89 PKG)

PIN NUMBER	SYMBOL	FUNCTION
1	GND	Ground
2	V <sub>IN</sub>	Power Input Pin
3	V <sub>OUT</sub>	Output Pin



# HL59xx Series High Speed Low Noise LDO

## Marking Rule

MARKING		
VOLTAGE(V)	Package	
	SOT23-5	SOT23
1.2	HL5912	HL12S
1.5	HL5915	HL15S
1.8	HL5918	HL18S
2.5	HL5925	HL25S
2.8	HL5928	HL28S
3.0	HL5930	HL30S
3.3	HL5933	HL33S

## Absolute Maximum Ratings

Supply Voltage .....-0.3V to 8V      Storage Temperature .....-50°C to 125°C

Operating Temperature .....-40°C to 85°C

Note: These are stress ratings only. Stresses exceeding the range specified under “Absolute Maximum Ratings” may cause substantial damage to the device. Functional operation of this device at other conditions beyond those listed in the specification is not implied and prolonged exposure to extreme conditions may affect device reliability.

## Thermal Information

Symbol	Parameter	Package	Max.	Unit
$\theta_{JA}$	Thermal Resistance (Junction to Ambient) (Assume no ambient airflow, no heat sink)	SOT23-5	500	°C/W
		SOT89	200	
$P_D$	Power Dissipation	SOT23-5	0.25	W
		SOT89	0.5	

Note:  $P_D$  is measured at  $T_a = 25^\circ\text{C}$



# HL59xx Series High Speed Low Noise LDO

## Electrical Characteristics

HL59xx series

( $T_a=25^{\circ}\text{C}$ )

Parameter	Symbol	Conditions	Min.	Typ.	Max.	Unit
Input Voltage	$V_{in}$	--	--	--	6	V
Output Voltage	$V_{out}$	$V_{in}=V_{out}+1\text{V}$ $1.0\text{mA}\leq I_{out}\leq 30\text{mA}$	$V_{out}\times 0.98$	--	$V_{out}\times 1.02$	V
Output Current*1	$I_{out}$	$V_{in}-V_{out}=1\text{V}$	--	500	--	mA
Line Regulation	$\frac{\Delta V_{out}}{\Delta V_{in}\cdot V_{out}}$	$4.3\text{V}\leq V_{in}\leq 8\text{V}$ $I_{out}=10\text{mA}$	--	0.05	0.2	%/V
Load Regulation	$\Delta V_{out}$	$V_{in}=4.3\text{V}$ $1.0\text{mA}\leq I_{out}\leq 100\text{mA}$	--	10	30	mV
Output voltage Temperature Coefficiency	$\frac{\Delta V_{out}}{T_a\cdot V_{out}}$	$I_{out}=30\text{mA}$ $0^{\circ}\text{C}\leq T_a\leq 70^{\circ}\text{C}$	--	$\pm 100$	--	Ppm/ $^{\circ}\text{C}$
Supply Current	$I_{ss}$	--	5	--	30	$\mu\text{A}$
PSRR	PSRR	$F=1\text{KHz}$ , $V_{in}=4.3\text{Vdc}+1\text{Vpp}$	--	68	--	dB

## Typical Application Circuit

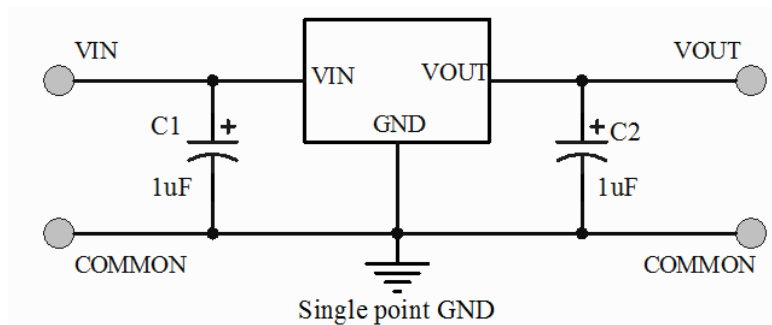
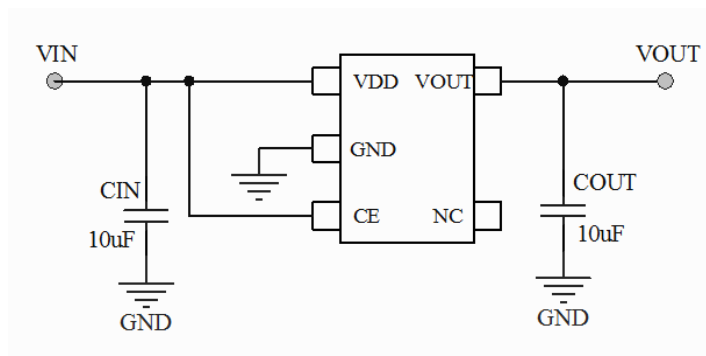

### Operational Explanation

#### <Output Voltage Control>

The P-channel MOSFET is connected to the V<sub>OUT</sub> pin, driven by the subsequent output signal. The output voltage at the V<sub>OUT</sub> pin is controlled and stabilized by a system of negative feedback. The IC's internal circuitry can shut-down by the CE pin's signal

#### <Low ESR Capacitors>

With the HL59xx series, a stable output voltage is achievable even if used with low ESR capacitors as a phase compensation circuit is built-in. In order to ensure the effectiveness of the phase compensation, we suggest that an output capacitor (C<sub>L</sub>) is connected as close as possible to the output pin (V<sub>OUT</sub>) and the GND pin. Please use an output capacitor with a capacitance value of at least 10uF. Also, please connect an input capacitor (C<sub>IN</sub>) of 10uF between the V<sub>IN</sub> pin and the GND pin in order to ensure a stable power input. Stable phase compensation may not be ensured if the capacitor runs out capacitance when depending on bias and temperature. In case the capacitor depends on the bias and temperature, please make sure the capacitor can ensure the actual capacitance.

#### <CE Pin>

The IC's internal circuitry can be shutdown via the signal from the CE pin with the HL59xx series. The operational logic of the IC's CE pin is selectable (please refer to the selection guide). Although the CE pin is equal to an inverter input with CMOS hysteresis, with either the pull-up or pull-down options, the CE pin input current will increase when the IC is in operation. We suggest that you use this IC with either a V<sub>IN</sub> voltage or a V<sub>SS</sub> voltage input at the CE pin. If this IC is used with the correct specifications for the CE pin, the operational logic is fixed and the IC will operate normally. However, supply current may increase as a result of through current in the IC's internal circuitry.

#### HL5933M5R with fast discharge function

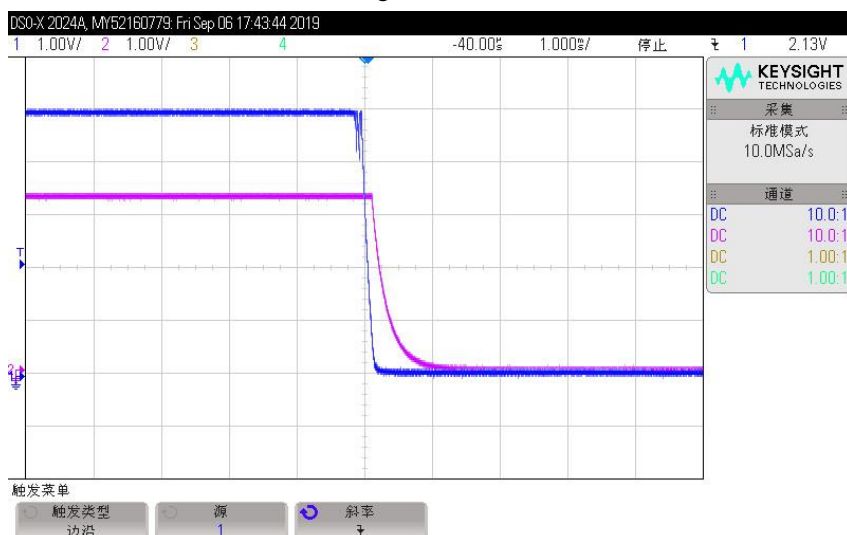

### Notes on Use

1. Please use this IC within the stated absolute maximum ratings. The IC is liable to malfunction should the ratings be exceeded.
2. Where wiring impedance is high, operations may become unstable due to noise and/or phase lag depending on output current. Please keep the resistance low between V<sub>IN</sub> and V<sub>SS</sub> wiring in particular.
3. Please wire the input capacitor (C<sub>IN</sub>) and the output capacitor (C<sub>L</sub>) as close to the IC as possible.

## Packaging Information

### SOT23-3 Outline Dimensions

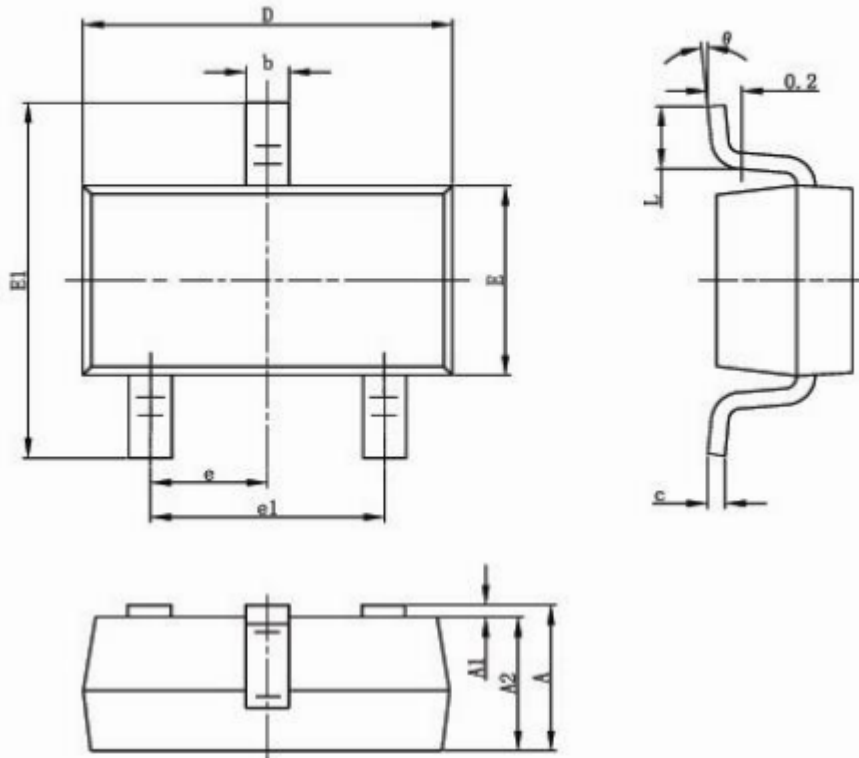

Symbol	Dimensions In Millimeters		Dimensions In Inches	
	Min	Max	Min	Max
A	1.050	1.250	0.041	0.049
A1	0.000	0.100	0.000	0.004
A2	1.050	1.150	0.041	0.045
b	0.300	0.500	0.012	0.020
c	0.100	0.200	0.004	0.008
D	2.820	3.020	0.111	0.119
E	1.500	1.700	0.059	0.067
E1	2.650	2.950	0.104	0.116
e	0.950(BSC)		0.037(BSC)	
e1	1.800	2.000	0.071	0.079
L	0.300	0.600	0.012	0.024
θ	0°	8°	0°	8°



# HL59xx Series High Speed Low Noise LDO

## SOT23-5 Outline Dimensions

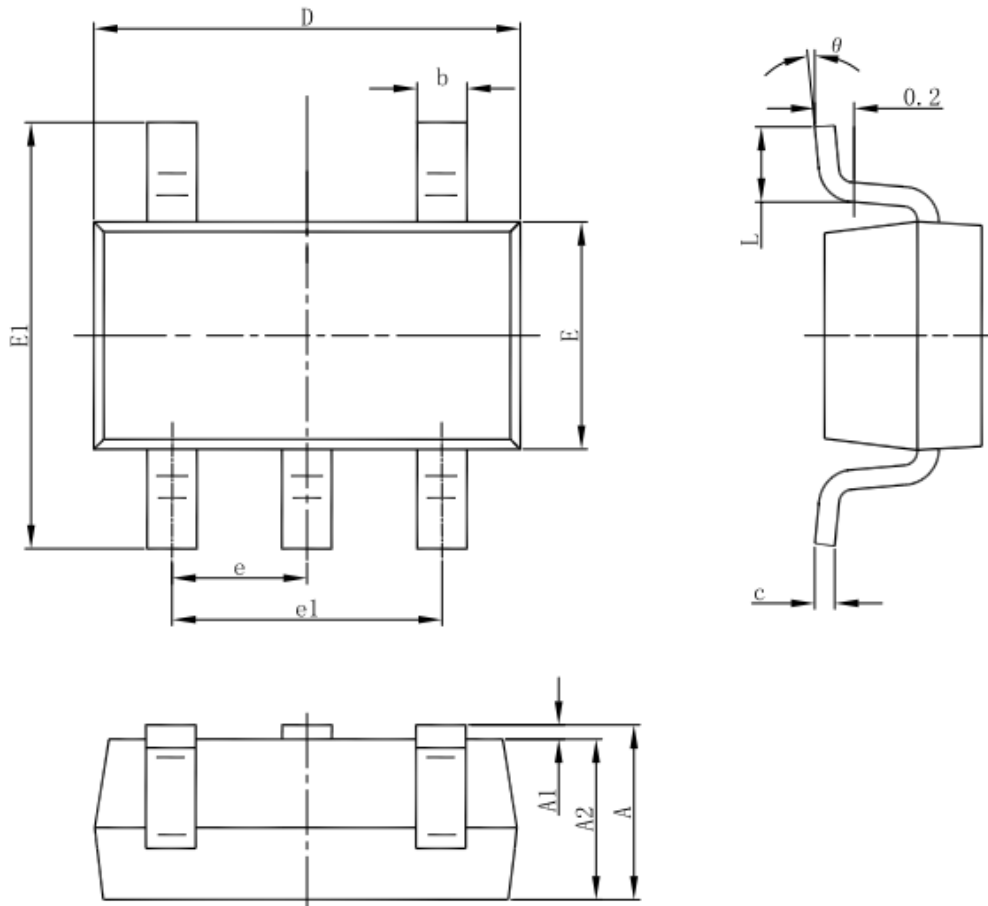

Symbol	Dimensions In Millimeters		Dimensions In Inches	
	Min	Max	Min	Max
A	1.050	1.250	0.041	0.049
A1	0.000	0.100	0.000	0.004
A2	1.050	1.150	0.041	0.045
b	0.300	0.500	0.012	0.020
c	0.100	0.200	0.004	0.008
D	2.820	3.020	0.111	0.119
E	1.500	1.700	0.059	0.067
E1	2.650	2.950	0.104	0.116
e	0.950(BSC)		0.037(BSC)	
e1	1.800	2.000	0.071	0.079
L	0.300	0.600	0.012	0.024
θ	0°	8°	0°	8°



### 3-pin SOT89 Outline Dimensions

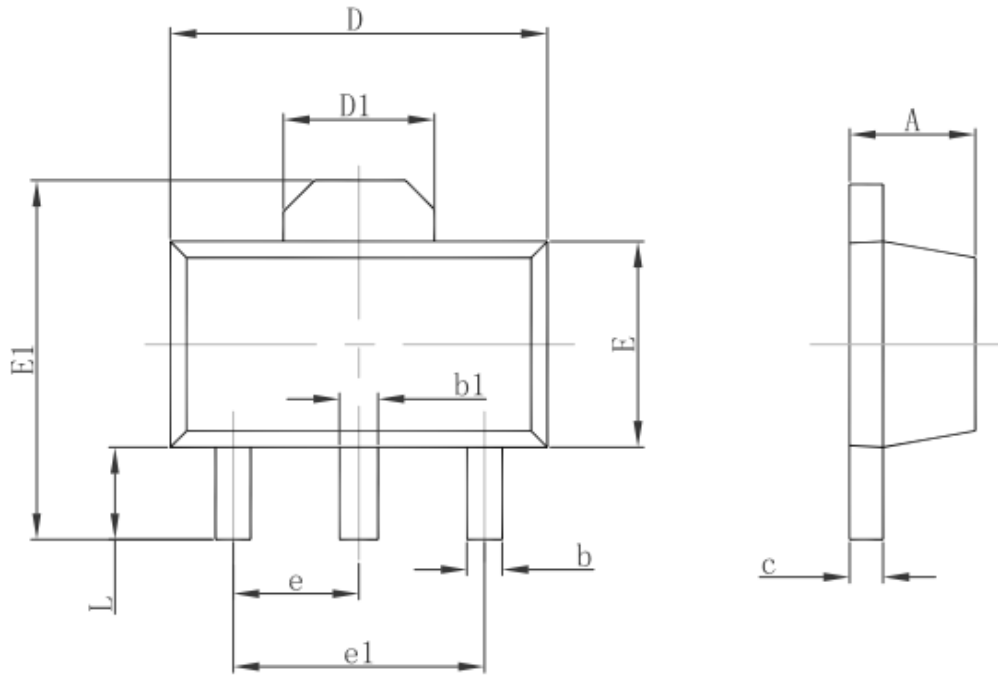

Symbol	Dimensions In Millimeters		Dimensions In Inches	
	Min.	Max.	Min.	Max.
A	1.400	1.600	0.055	0.063
b	0.320	0.520	0.013	0.020
b1	0.400	0.580	0.016	0.023
c	0.350	0.440	0.014	0.017
D	4.400	4.600	0.173	0.181
D1	1.550 REF.		0.061 REF.	
E	2.300	2.600	0.091	0.102
E1	3.940	4.250	0.155	0.167
e	1.500 TYP.		0.060 TYP.	
e1	3.000 TYP.		0.118 TYP.	
L	0.900	1.200	0.035	0.047